

MODERNIZATION OF THE ELECTRIC DRIVE OF THE GRAIN OF TRANSHIPMENT NORIA

Gordienko O.M. – student, sashagordienko8@gmail.com

Koshkin D.L. - Ph.D., docent, koshkin.mnau@gmail.com

Mikolaev national agrarian university

Relevance of research. Recently, as a source of regulated DC voltage used, as a rule, thyristor converters. The operational qualities of the conveyor (productivity, convenience and simplicity of service and reliability of work) in many respects depend on how well the control system is developed [1]. The requirements of safety, ease and convenience of manipulation, optimum speed are put forward to control systems. Complete thyristor electric drives meet all these requirements. Their use allows to fulfill all requirements of technological process, and also promotes complex automation of the enterprise.

The purpose of the work is to develop a control system for the electric drive of the transport noria, which would provide appropriate conditions for the optimality of the technological process of the elevator.

The belt-type noria is intended for vertical transportation of grain and products of its processing. It is applied at the enterprises on processing of grain and

its products. The noria consists of a head with a drive, a shoe, straight pipes, a pipe with an inspection hatch, pipes with a tension and inspection hatches, pipes with an aspiration branch pipe, pipes with an aspiration branch pipe and a sensor, latches, a branch branch pipe, buckets with a bottom and without bottom. The set of delivery of a noria includes the basic knots: a head, drives, latches, a shoe, pipes, ladles with a bottom and without a bottom, a belt, a control board. Norias are completed with sections of pipes of the following types: direct, with an inspection hatch, with a tension and inspection hatches, with an aspiration branch pipe and the sensor, in addition there can be pipes with a roller and explosion-discharge.

The start of the noria is carried out before the start of the download in the following sequence:

- the traction body is driven by the drive;
- make sure of the stable movement of the noria at idle;
- open the latch of the receiving sock of the noria shoe;
- include the supply of grain to the noria through the receiving sock;
- regulate the supply of the product, preventing the overload of the noria [1, 2].

The operation of the electric drive, according to the requirements of the technological process, provides a control system based on a thyristor converter, the electric drive of the grain reloading conveyor must provide a constant speed of the conveyor belt at any allowable load [3]. High accuracy of speed control of the electric drive can be reached by means of the complete electric drive on the basis of the thyristor converter ETU 3601. Its advantages include high efficiency, high reliability, low cost and simplicity of adjustment.

The electric drive provides a bandwidth of the closed speed control system not less than 200 rad / s, allows overload current of about 6 A for a time of 0.2 s. Exceeding the temperature of different parts of the electric drive should not be higher than the limits specified in the technical conditions for components [4]. Thyristor converter - without inertial element, a system of equations describing the electric drive. In the event of a short circuit of the thyristors in the event of a DC circuit, the current-limiting reactor must limit the rate of increase of the emergency current so that it does not exceed the value dangerous for the thyristors during the operation of protective devices.

Each parameter has its own regulator, so you can ensure the optimal settings of each circuit. The control circuit is determined by the outer circuit. The output signal of the speed controller is the master for the internal circuit. The current circuit is subordinate to the speed circuit [5].

On the basis of the specified conditions of optimality of passing of technological process of work of the conveyor, the structural scheme of system of the subordinate control of coordinates of the electric drive was developed.

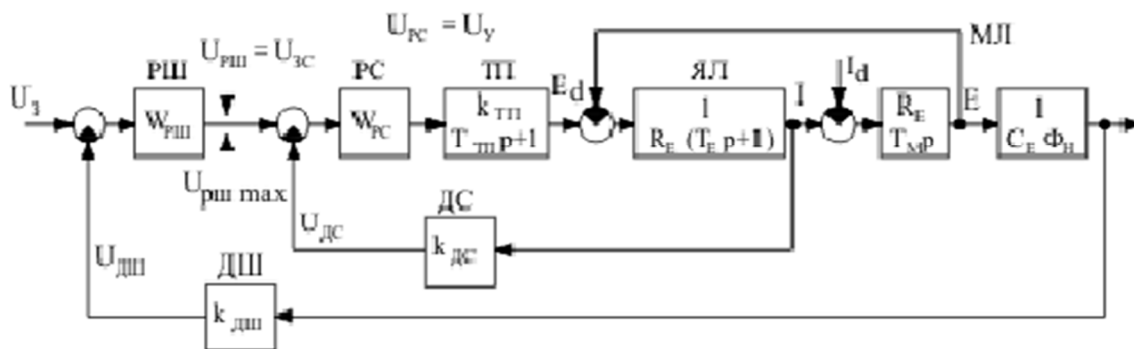

Fig. 1. Block diagram of the system of subordinate control of coordinates of the electric drive: РШ - speed regulator; РС - current regulator; ТТ - thyristor converter; ЯЛ - anchor chain of the engine; МЛ - mechanical part of the engine; ДС - current sensor; ДШ - speed sensor.

Advantages of the developed control system:

- the possibility of implementing the optimal control laws of each parameter;
- ease of limiting the maximum values of the adjustable value by limiting the signal at the input of the corresponding controller ;
- simplifies the calculation, setup and implementation.

Disadvantages of the developed control system:

- system speed decreases with increasing number of control circuits;
- grows a small time constant of control circuits.

Conclusion. Assessing the stability of the control system by the logarithmic criterion, we can conclude that the system is stable. Since the margin of stability in amplitude is equal to $\Delta L = 20,5$ dB at a frequency of 408 rad / s. The phase stability margin is equal to $\Delta\varphi = 63.1$ at a frequency of 53.7 rad / s. According to the reaction of the system to the step action, it is possible to determine the indicators of control quality, which are realized by this system. Thus, as the transmission ratio of the speed controller increases, the overregulation and the transition process decrease.

Literature

1. Башарин Н.К. Управление электроприводами: Учебное пособие для вузов. / Н. К. Башарин, В. А. Новиков, Г. Г. Соколовский. — Л.: Энергоиздат, 1982 г.
2. Пілецький В.Т. Вибір елементів реверсивних тиристорних перетворювачів електроприводів постійного струму. / В. Т. Пілецький. — К.:ІСДО, 1994 г.
3. Долин П. А. Справочник по технике безопасности. / П. А. Долин. — М.: Энергоатомиздат, 1984 г.
4. Ключев В.И. Электропривод и автоматизация общепромышленных механизмов: Учебник для вузов. / В. И. Ключев, В. М. Терехов. — М.: Энергия, 1980 г.
5. Комплектные тиристорные электроприводы: Справочник / [Евзеров И.Х., Горобец А.С., Мошкович Б.И. и др.]. Под ред. В. М. Перельмутера. — М.: Энергоатомиздат, 1998 г.