

UDC 66.094.8:661.5

*S.I. Kuznietsov^a, D.S. Kachuk^b, O.O. Venger^a, E.S. Ivkina^a***METHOD OF NEUTRALIZATION OF NITROGEN OXIDES IN AREA OF LOW-TEMPERATURE PLASMA**^a Kherson National Technical University, Kherson, Ukraine^b Mykolaiv National Agrarian University, Mykolaiv, Ukraine

In the production of 1 ton of oxalic acid, 2000 m³ of gases with an average content of 2–2.5% of nitrogen oxides are emitted into the atmosphere. The existing methods of air purification from nitrous gases have a number of disadvantages and therefore cannot be widely used in industry. Based on theoretical and experimental studies, a new method for the thermal decomposition of nitrogen oxides has been developed, which provides for the sanitary purification of waste gases in the production of oxalic acid, up to the maximum permissible concentrations. The process of thermal decomposition of nitrogen oxides in the temperature range from 500 to approximately 5000°C has been studied. To achieve such temperatures, an arc plasma torch with a tungsten cathode and a copper anode was used. The degree of decomposition was determined by measuring the NO concentration at the inlet and outlet by the evacuated flask method. The effects of gaseous (hydrogen, ammonia, methane, natural gas), liquid (kerosene, gasoline, fuel oil), and solid reducing agents (coke, coal, graphite) on the decomposition reaction of nitrogen oxides were also studied.

Keywords: thermal decomposition, nitrogen oxides, sanitary cleaning of waste gases, oxalic acid, production, atmosphere.

DOI: 10.32434/0321-4095-2024-153-2-32-38

Introduction

The problem of air pollution has the most diverse aspects of the impact on the environment and human. According to estimates of specialists, over half a billion hectares of arable land, two-thirds of forests, more than 150 species of animals and birds have already been lost on Earth. Millions of tons of steel and other materials are lost annually from the corrosion of metals. Human diseases have become more frequent cardiovascular and cancerous [1]. If further not to take the necessary measures, the processes of industrialization will lead to the rapid depletion and disappearance of biological resources. Moreover, this is not the last role will play a pollution of atmospheric air [2].

Humanity has great potential for adapting to the environment. However, for a normal life it needs certain conditions in which it has been formed over many millennia. To ensure the correct and

harmonious development of people, all factors that adversely affect their health should be eliminated. In industrialized countries, where the heat and power, chemical, metallurgical, and petrochemical industries are concentrated, the atmospheric air is significantly polluted. Among the harmful substances, nitrous gases are at the forefront.

Currently, there are various methods of cleaning gases from nitrogen oxides. The choice of air purification method depends on a large variety of technological processes in which nitrous gases are released into the atmosphere. Exhaust gases differ in temperature, quantity, degree of NO oxidation, content of nitrogen oxides, oxygen and other impurities.

Presently the question of neutralization of oxides of nitrogen is cardinally decided in the production of nitric acid under pressure. The method of catalytic neutralization of nitrogen oxides on a palladium catalyst has been introduced here. However, the catalytic

© S.I. Kuznietsov, D.S. Kachuk, O.O. Venger, E.S. Ivkina, 2024



This article is an open access article distributed under the terms and conditions of the Creative Commons Attribution (CC BY) license (<https://creativecommons.org/licenses/by/4.0/>).

S.I. Kuznietsov, D.S. Kachuk, O.O. Venger, E.S. Ivkina

method is associated with the installation of complex equipment and the use of expensive catalyst. In addition, the catalytic method is suitable for systems operating under pressure [3]. It is applicable to gases that have in their composition no more than 1% of nitrogen oxides and 4–5% of oxygen.

In industry, there are a large number of sources, emitting into the atmosphere a nitrous gas containing up to 3–5% of nitrogen oxides and up to 10–20% of oxygen. Emissions differ in their character (continuous and periodic), and in terms of their productivity (from several hundred to several million m³/h). Such systems include waste gases produced by oxalic acid, emitting to the atmosphere 2000 m³/h of nitrous gas with a content of 2.0–2.5% of oxides and up to 10% of oxygen. Naturally, the catalytic method of purifying gases from nitrogen oxides for such systems is unacceptable.

Other well-known methods, such as alkaline ones, are also less effective under these conditions, which are characterized by cumbersome and low purity (up to 60–70%). Until recently, neither in our country, nor abroad, the issue of cleaning exhaust gases from nitrogen oxides in the production of oxalic acid has any positive solution. The purpose of this work is to find an effective method for the sanitary cleaning of waste gases from nitrogen oxides in the production of oxalic acid.

Experimental and theoretical considerations

Production of oxalic acid is based on oxidation of sucrose with nitric acid [4]:

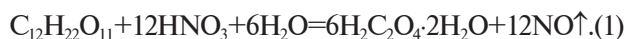

In this case, the reduction of nitric acid to nitric oxide occurs. Other nitrogen oxides may also be formed. As a result, in the production of 1 ton of oxalic acid, 2000 m³ of gases with an average content of 2–2.5% of nitrogen oxides are emitted into the atmosphere.

Theoretical studies and techno-economic calculations showed that for low-power systems with a high content of nitrogen oxides and oxygen in the gas (and waste gases in the production of oxalic acid refer specifically to such systems), it is most expedient to construct treatment plants operating on the principle of thermal decomposition of nitrogen oxides on neutral products [5].

This method is based on the decomposition reaction of nitric oxide:



A method differs in simplicity, compactness, small capital and operating costs.

Oxygen compounds of nitrogen can exist in the form of the following oxides: nitrous oxide N₂O; nitric oxide NO; nitrogen dioxide NO₂ and its dimer, dinitrogen tetroxide N₂O₄; dinitrogen trioxide N₂O₃; and dinitrogen pentoxide N₂O₅.

Depending on the nitrogen oxidation level, oxygen compounds of nitrogen possess different physicochemical properties. For example, dinitrogen tetroxide (N₂O₄) is an active compound reacting with almost all inorganic and organic compounds. Nitric oxide (NO) is an indifferent compound that does not react with most compounds. Other properties of various nitrogen oxides differ sharply.

The degree of oxidation of nitrogen is largely determined by temperature. Depending on the temperature, there may be some nitrogen oxides. In the presence of oxygen or ozone and low temperature, the oxidation reaction of nitric oxide proceeds spontaneously and irreversibly in the following direction:



Dinitrogen pentoxide can exist in the solid state at low temperatures. When heated in a gas form, it dissociates into NO₂ and NO₃. Nitrogen dioxide easily polymerizes into dinitrogen tetroxide in a reversible reaction:



The degree of polymerization depends on the temperature. At a temperature of 21.15°C, the N₂O₄ liquid dissociates into NO₂ molecules. At temperatures above 140°C, the reaction equilibrium is completely shifted to the right and only NO₂ can exist in the gas phase. With further heating of nitrogen dioxide, it decomposes:



The complete decomposition of NO₂ into nitric oxide and oxygen occurs at a temperature of 600°C. Nitric oxide is stable. However, at temperatures above 1000°C it is in a very dissociated state:



Thus, the temperature range of the existence of various nitrogen oxides in the gas phase can be represented as follows:

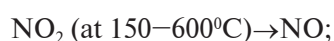
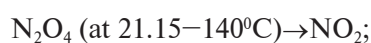

NO (at 600–1000°C) → N₂ + O₂.

Heating higher oxides of nitrogen can be achieved by decomposing them into lower, down to elemental nitrogen and oxygen. This regularity is the basis of the developed method.

The reaction of formation and decomposition of nitric oxide is reversible:



The equilibrium concentration of nitric oxide, which is obtained from nitrogen and oxygen in the temperature range from 1000 K to 4000 K, can be determined by the following formula:

$$\lg X = -\frac{4726}{T} - 2.152. \quad (8)$$

The rate at which dynamic equilibrium is established by reaction (6) is determined by the following equation of the second order:

$$\frac{dx}{dt} = K_1(C_{\text{N}_2} - 0.5X) \cdot (C_{\text{O}_2} - 0.5X) - K_2X^2, \quad (9)$$

where X is the current concentration of nitric oxide; C_{N₂} and C_{O₂} are concentration of nitrogen and oxygen in initial gas (vol.%), respectively; K₁ and K₂ are the rate constants of forward and reverse reactions, respectively.

The temperature dependences of the equilibrium concentration of nitric oxide, X, (Eq. (8)) and dynamic equilibrium time, τ, (Eq. (9)) are shown in Table.

The value of the equilibrium concentration of nitric oxide

Temperature, K	Equilibrium concentration of nitric oxide, %	Dynamic equilibrium time, s
1000	0.02	4·10 ⁵
1500	0.044	1.8·10 ²
2000	1.34	1.0
2500	2.4	5·10 ⁻⁵
3000	4.0	7·10 ⁻⁹

By using high temperatures, it is possible not only to synthesize nitric oxide from the elements of nitrogen and oxygen, but also to decompose it into starting materials.

Table shows that from the point of view of sanitary disposal of nitrous gases, the residual equilibrium concentration of nitrogen oxides, achieved by simple thermal decomposition, is too high, and the time for establishing the equilibrium

concentrations at low temperatures is too long. For example, by heating the nitrous gas to a temperature of 2000 K, its concentration can be easily reduced to 1.34%. This will take only 1 second. But in order to reduce the concentration to 0.02%, it will take 4·10⁵ s already, which is impossible under production conditions, since will be associated with the installation of the reaction apparatus with a capacity of 1000 m³ per 1 m³ of nitrous gas. It should be added that the conditions for cooling the gas must correspond to a gradual decrease in concentration to an equilibrium state. Otherwise, the residual concentrations of nitrogen oxides in the nitrous gas will be higher than the equilibrium, and the degree of their thermal decomposition will be reduced.

It follows from Eq. (9) that the rate of formation of nitrogen oxides is directly proportional to the content in the mixture of oxygen. If oxygen is removed from the system in the process of decomposition, the rate of formation of nitrogen oxides and the equilibrium concentration can be reduced. This provision was also used in the developed method of thermal decomposition of nitrogen oxides.

Gaseous, liquid or solid reducing agents can be used as oxygen-binding components. For example, hydrogen, carbon monoxide, methane, ammonia, kerosene, gasoline, fuel oil, coke, coal, graphite, etc. The same combustible components are used to heat the gas to the decomposition temperature.

Of particular interest was the study of the process of thermal decomposition of nitrogen oxides in the temperature range from 500 to 5000°C. To achieve such temperatures, an arc plasma torch [6] with a power of 20 kW with a tungsten cathode and a copper anode, which were cooled with running water (Fig. 1), was used. The arc stabilization is magnetic-vortex. The position of the plasma torch is vertical with the lower position of the cathode. A reactor 2 was connected to the exhaust nozzle of the plasma torch, which simultaneously served as a heat exchanger for preheating the gas. Nitrogen supplied from cylinder 10 was used as a plasma-forming gas. Liquid dinitrogen tetroxide, was used as a source of nitrogen oxides and evaporated from cylinder 9 located in a thermostat.

Plasma-forming gas with a temperature of 1000–15000°C leaving the plasma torch enters the reactor and is mixed with nitrous gas, which is preheated in a heat exchanger to a temperature of 600°C. As a result of mixing the gas flows, the mass-average temperature of the mixture in the reactor ranges from 1000°C to 3500°C. The concentration of nitrogen oxides at the inlet and outlet was determined by the method of evacuated samples. The installation is equipped with a set of instrumentation for determining flow, temperature, etc.

The electric circuit of the plasma torch is shown in Fig. 2. It is designed on VKDu-150 type diodes, connected via a bridge circuit. The plasma torch is powered from the AC network 50 Hz, 220 V through an autotransformer of the type RNO-0-250. In the circuit of the anode and cathode installed ballast inductive resistances, which serve to protect the diodes from short circuit and steady burning of the arc of the plasma torch.

The described power scheme provides a good current-voltage characteristic of the plasma torch, whose work is highly stable and noiseless. For proper and stable operation, a plasma-forming gas and a cooling fluid are first introduced into the plasma torch, and then voltage is applied to the anode and cathode. When the voltage reaches 65–75 V, the electrodes are closed and divorced at a distance of 4–5 mm. A gas mixture with a given concentration of nitrogen oxides

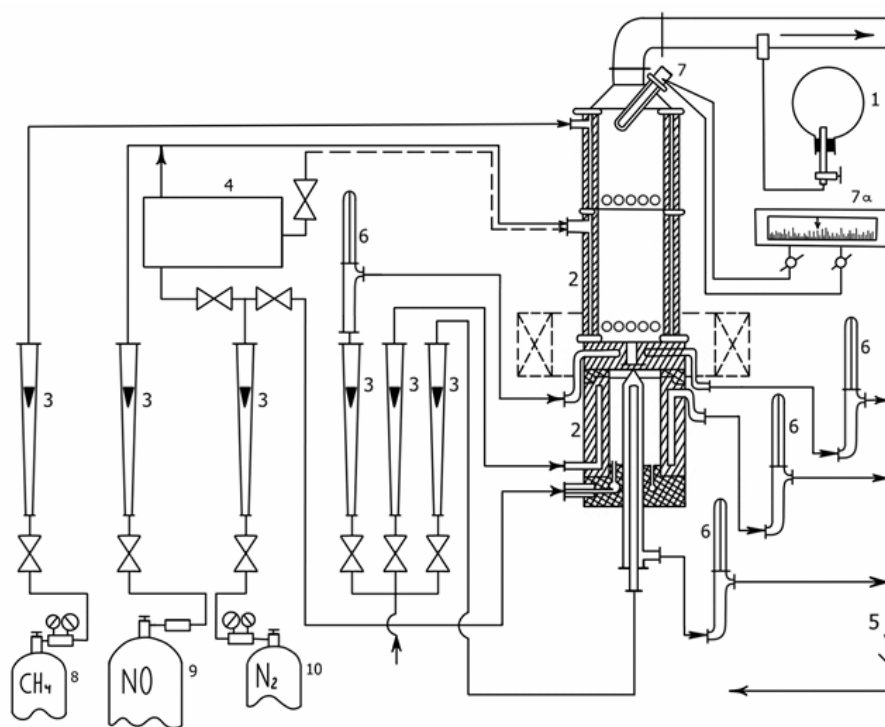

Fig. 1. Technological scheme of the plasma torch: 1 – plasma torch; 2 – reactor; 3 – rotameters; 4 – receiver; 5 – air; 6 – pressure gauges; 7 – thermocouple; 8 – balloon with CH_4 ; 9 – balloon with NO ; 10 – balloon with N_2 ; 11 – sampling point

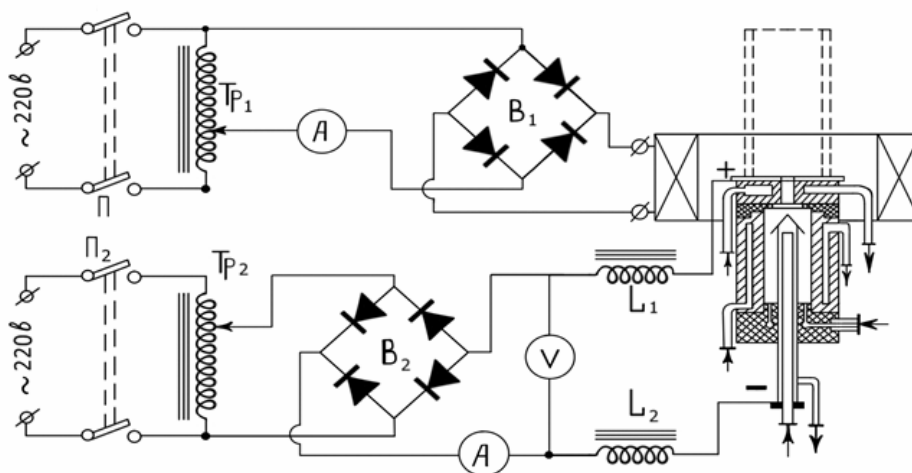

Fig. 2. Electric circuit of the plasma torch

is introduced into the working plasma torch. Then the gas mixture is heated to a temperature of 2000–4000°C. At this temperature, nitrogen oxides decompose into elements, nitrogen and oxygen. The degree of decomposition is determined by measuring the concentration of NO at the inlet and outlet by the method of evacuated flasks.

Results and discussion

The research results are presented in Fig. 3, which shows the dependence of the degree of decomposition of nitrogen oxides on their initial concentration in the gas mixture.

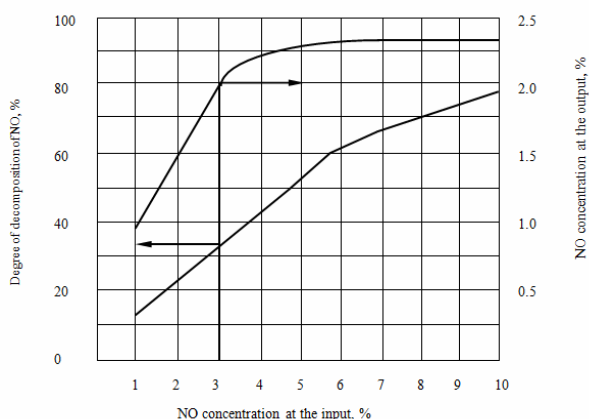

Fig. 3. Dependence of the degree of decomposition of nitrogen oxides on the initial concentration of NO

The initial concentration of nitrogen oxides was from 0.01% to 10%, and the average bulk temperature in the reactor was 2000–2100°C. The temperature in the reactor was determined by calculation based on the heat balance of the plasma torch.

With an increase in the concentration of nitrogen oxides, the degree of their decomposition grew. With an initial concentration of nitrogen oxides in the gas of 5%, the degree of decomposition was 52% at a concentration of NO at the output of 2.4%. With an increase in the initial concentration of nitrogen oxides from 5 to 10%, the degree of their decomposition increased to 77%, while the concentration of NO at the outlet remained 2.4%.

The constant value of the concentration of nitrogen oxides at the outlet (at the inlet of 4% and above) is explained by the approach of the system to the equilibrium state at a given temperature (Table).

It should be noted that the concentration of nitrogen oxides after decomposition remains high. This degree of decomposition in terms of sanitization is unsatisfactory. Therefore, the second series of experiments was devoted to the question of studying the effect of reducing agents on the decomposition of nitrogen oxides.

As reducing agents, gaseous (hydrogen, ammonia,

methane, natural gas), liquid (kerosene, gasoline, fuel oil) and solids (coke, coal, graphite) substances were investigated.

Studies of gaseous and liquid reducing agents showed that in their presence the equilibrium of the decomposition reaction of nitrogen oxides is shifted to the right side, i.e. towards the decomposition of NO into N₂ and O₂. The degree of decomposition does not depend on the nature of the liquid or gaseous reducing agents. Figure 4 shows the results of studies on the decomposition of nitrogen oxides in the presence of some reducing agents at 2000°C.

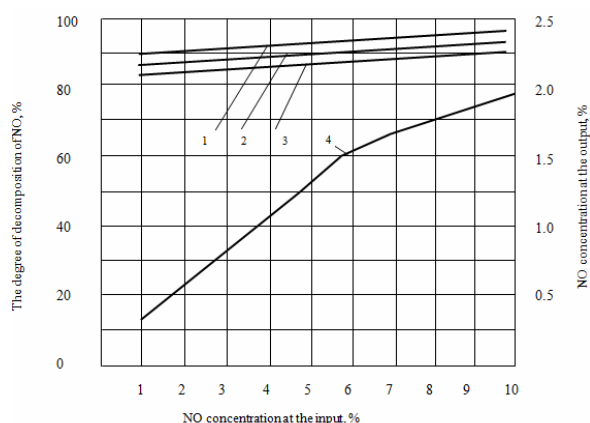

Fig. 4. The dependence of the degree of decomposition of nitrogen oxides on the initial concentration of NO: 1 – ammonia reducing agent; 2 – hydrogen reducing agent; 3 – natural gas reducing agent; 4 – without reducing agent

The investigated reducing agents almost equally affect the decomposition of nitrogen oxides. Their efficiency differs by 3–5%. The concentration of nitrogen oxides after decomposition can be reduced to 0.1–0.3% at an initial concentration of 2–3% and if we take into account the cost of reducing agents, then preference should be given to natural gas.

Analyzing the experimental data, we can conclude that the degree of decomposition of nitrogen oxides in the presence of gaseous or liquid reducing agents increases, and the equilibrium content of nitrogen oxides in the exhaust gases decreases by 5–10 times. If the absolute amount of gases emitted into the atmosphere is small (up to 5–10 thousand m³/hour) decomposition of nitrogen oxides in the presence of gaseous or liquid reducing agents can serve as a method of sanitary cleaning of gases. With a larger volume of emitted gases, this method does not provide the maximum permissible concentration of nitrogen oxides in the surface layer.

Solid reducing agents such as coke, coal, and graphite behave quite differently. These components interact with nitrogen oxides by the reaction:



The process of decomposition of nitrogen oxides in the presence of coke for 2.5% of gas begins at a temperature of 500°C (Fig. 5).

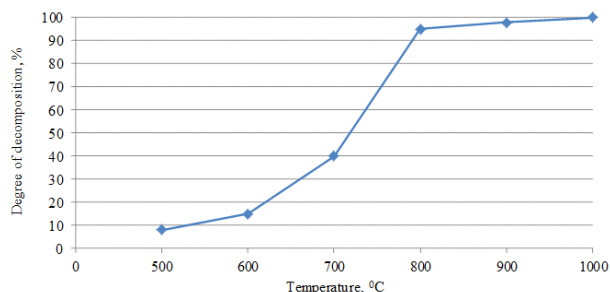

Fig. 5. Influence of temperature on the degree of decomposition of nitrogen oxides in the presence of coke

As the temperature rises, the rate and degree of decomposition increase. At 800°C, a fairly high degree of decomposition of nitrogen oxides is observed (96%). With a further increase in temperature, the degree of decomposition increases and approaches 100% at 1000°C.

Conclusions

An effective method has been developed for cleaning exhaust gases from nitrogen oxides in the production of oxalic acid, based on their thermal decomposition at high temperatures in the presence of reducing agents. It has been established that with the help of this method, the concentration of nitrogen oxides can be reduced from any initial concentration to the equilibrium one at a certain temperature.

REFERENCES

1. *Advancing environmental exposure assessment science to benefit society* / Caplin A., Ghandehari M., Lim C., Glimcher P., Thurston G. // *Nat. Commun.* – 2019. – Vol.10. – No. 1. – Art. No. 1236.
2. *Investigating the effects of stove emissions on ocular and cancer cells* / Karakocak B.B., Patel S., Ravi N., Biswas P. // *Sci. Rep.* – 2019. – Vol.9. – Art. No. 1870.
3. *Exploring the ternary interactions in Cu-ZnO-ZrO₂ catalysts for efficient CO₂ hydrogenation to methanol* / Wang Y., Kattel S., Gao W., Li K., Liu P., Chen J.G., Wang H. // *Nat. Commun.* – 2019. – Vol.10. – No. 1. – Art. No. 1166.
4. *Guru M., Bilgesu A.Y., Pamuk V.* Production of oxalic acid from sugar beet molasses by formed nitrogen oxides // *Bioresour. Technol.* – 2001. – Vol.77. – No. 1. – P.81-86.

5. *Nitrogen transformation during pyrolysis of oilfield sludge with high polymer content* / Wang Y., Dong B., Fan Y., Hu Y., Zhai X., Deng C., Xu Y., Shen D., Dai X. // *Chemosphere.* – 2019. – Vol.219. – P.383-389.

6. *Chen S., Yan Z., Jiang F.* Arc discharge and pressure characteristics in pulsed plasma gas of PAW // *Int. J. Adv. Manuf. Technol.* – 2019. – Vol.102. – P.695-703.

Received 29.04.2023

МЕТОД НЕЙТРАЛІЗАЦІЇ ОКСИДІВ АЗОТУ В ЗОНІ НИЗЬКОТЕМПЕРАТУРНОЇ ПЛАЗМИ

С.І. Кузнєцов, Д.С. Качук, О.О. Венгер, Є.С. Івкіна

Під час виробництва шавлевої кислоти в атмосферу виділяється до 2000 м³ газів із середнім вмістом у них 2–2,5% оксидів азоту. Існуючі методи очищення повітря від нітрозних газів мають низку недоліків і тому не можуть широко застосовуватися в промисловості. У роботі запропоновано новий ефективний метод санітарного очищення відпрацьованих газів від оксидів азоту при виробництві шавлевої кислоти. Він розроблений на основі теоретичних та експериментальних досліджень термічного розкладання оксидів азоту при високих температурах. Метод передбачає санітарне очищення великих об'ємів відпрацьованих газів під час виробництва шавлевої кислоти до максимально допустимих концентрацій. Досліджено процес термічного розкладання оксидів азоту в інтервалі температур від 500 до приблизно 5000°C. Для досягнення таких температур використовувався дуговий плазмотрон з вольфрамовим катодом і мідним анодом. Ступінь розкладання визначався вимірюванням концентрації NO на вході та на виході методом евакуйованих колб. Також досліджено вплив на реакцію розкладання оксидів азоту газоподібних (водень, амоніак, метан, природний газ), рідких (гас, бензин, мазут), твердих відновників (кокс, вугілля, графіт).

Ключові слова: термічне розкладання, оксиди азоту, санітарне очищення відпрацьованих газів, шавлева кислота, виробництво, атмосфера.

METHOD OF NEUTRALIZATION OF NITROGEN OXIDES IN AREA OF LOW-TEMPERATURE PLASMA*S.I. Kuznietsov*^{a,*}, *D.S. Kachuk*^b, *O.O. Venger*^a, *E.S. Ivkina*^a^a Kherson National Technical University, Kherson, Ukraine^b Mykolaiv National Agrarian University, Mykolaiv, Ukraine* e-mail: ksieko1@gmail.com

In the production of 1 ton of oxalic acid, 2000 m³ of gases with an average content of 2–2.5% of nitrogen oxides are emitted into the atmosphere. The existing methods of air purification from nitrous gases have a number of disadvantages and therefore cannot be widely used in industry. Based on theoretical and experimental studies, a new method for the thermal decomposition of nitrogen oxides has been developed, which provides for the sanitary purification of waste gases in the production of oxalic acid, up to the maximum permissible concentrations. The process of thermal decomposition of nitrogen oxides in the temperature range from 500 to approximately 5000°C has been studied. To achieve such temperatures, an arc plasma torch with a tungsten cathode and a copper anode was used. The degree of decomposition was determined by measuring the NO concentration at the inlet and outlet by the evacuated flask method. The effects of gaseous (hydrogen, ammonia, methane, natural gas), liquid (kerosene, gasoline, fuel oil), and solid reducing agents (coke, coal, graphite) on the decomposition reaction of nitrogen oxides were also studied.

Keywords: thermal decomposition; nitrogen oxides; sanitary cleaning of waste gases; oxalic acid; production; atmosphere.

REFERENCES

1. Caplin A, Ghandehari M, Lim C, Glimcher P, Thurston G. Advancing environmental exposure assessment science to benefit society. *Nat Commun.* 2019; 10(1): 1236. doi: 10.1038/s41467-019-09155-4.
2. Karakocak BB, Patel S, Ravi N, Biswas P. Investigating the effects of stove emissions on ocular and cancer cells. *Sci Rep.* 2019; 9: 1870. doi: 10.1038/s41598-019-38803-4.
3. Wang Y, Kattel S, Gao W, Li K, Liu P, Chen JG, et al. Exploring the ternary interactions in Cu-ZnO-ZrO₂ catalysts for efficient CO₂ hydrogenation to methanol. *Nat Commun.* 2019; 10(1): 1166. doi: 10.1038/s41467-019-09072-6.
4. Guru M, Bilgesu AY, Pamuk V. Production of oxalic acid from sugar beet molasses by formed nitrogen oxides. *Bioresour Technol.* 2001; 77: 81-86. doi: 10.1016/s0960-8524(00)00122-x.
5. Wang Y, Dong B, Fan Y, Hu Y, Zhai X, Deng C, et al. Nitrogen transformation during pyrolysis of oilfield sludge with high polymer content. *Chemosphere.* 2019; 219: 383-389. doi: 10.1016/j.chemosphere.2018.11.171.
6. Chen S, Yan Z, Jiang F. Arc discharge and pressure characteristics in pulsed plasma gas of PAW. *Int J Adv Manuf Technol.* 2019; 102: 695-703. doi: 10.1007/s00170-018-3198-9.